



## REQUEST FOR QUOTATION (RFQ)

NAME & ADDRESS OF FIRM:	DATE: 19 September 2014
	REFERENCE: RfQ14/00876

Dear Sir / Madam:

We kindly request you to submit your quotation for **furniture for SYSLAB Centre in Balti**, as detailed in Annex 1 of this RFQ. When preparing your quotation, please be guided by the form attached hereto as Annex 2.

Quotations may be submitted on or before **26 September 2014, 16:30 (Moldova local time)** and via e-mail or courier mail to the address below:

**United Nations Development Programme in Moldova**  
**131, 31 August 1989 Street, MD-2012 Chisinau, Republic of Moldova**  
**Attention: Registry Office/Procurement**  
**[tenders-Moldova@undp.org](mailto:tenders-Moldova@undp.org)**

Quotations shall be submitted in English or Romanian, duly signed and stamped and shall be marked with the note "**RfQ14/00876: supply of furniture for SYSLAB Centre in Balti**".

Quotations submitted by email must be limited to a maximum of 5MB, virus-free and no more than 5 email transmissions. They must be free from any form of virus or corrupted contents, or the quotations shall be rejected.

It shall remain your responsibility to ensure that your quotation will reach the address above on or before the deadline. Quotations that are received by UNDP after the deadline indicated above, for whatever reason, shall not be considered for evaluation. If you are submitting your quotation by email, kindly ensure that they are signed and in the .pdf format, and free from any virus or corrupted files.

Please take note of the following requirements and conditions pertaining to the supply of the abovementioned good/s:

Delivery Terms [INCOTERMS 2010]	<input type="checkbox"/> FCA <input type="checkbox"/> CPT <input type="checkbox"/> CIP <input checked="" type="checkbox"/> DAP
Customs clearance, if needed, shall be done by:	<input type="checkbox"/> UNDP <input checked="" type="checkbox"/> Supplier/Offeror <input type="checkbox"/> Freight Forwarder
Exact Address of Delivery Location (identify all, if multiple)	13, Decebal str., 2 <sup>nd</sup> floor, Balti (Balti SYSLAB Centre's Office)
Latest Expected Delivery Date and Time (if delivery time exceeds this, quote may be rejected by UNDP)	<input checked="" type="checkbox"/> up to 21 calendar days from the issuance of the Purchase Order (PO)
Delivery Schedule	<input checked="" type="checkbox"/> Required
Preferred Currency of Quotation <sup>1</sup>	<input type="checkbox"/> United States Dollars <input type="checkbox"/> Euro <input checked="" type="checkbox"/> Moldovan Lei
Value Added Tax on Price	<input checked="" type="checkbox"/> Must be exclusive of VAT and other applicable indirect

<sup>1</sup> Local vendors must comply with any applicable laws regarding doing business in other currencies. Conversion of currency into the UNDP preferred currency, if the offer is quoted differently from what is required, shall be based only on UN Operational Exchange Rate prevailing at the time of competition deadline.

Quotation	taxes
After-sales services required	<input checked="" type="checkbox"/> Warranty on Parts and Labor for minimum period of 1 year <input checked="" type="checkbox"/> Others: fixing/assembling of furniture in the office premises
Deadline for the Submission of Quotation	<b>26 September 2014, 16:30 (Moldova local time)</b>
All documentations, including catalogs, instructions and operating manuals, shall be in this language	<input checked="" type="checkbox"/> English <input type="checkbox"/> French <input type="checkbox"/> Spanish <input checked="" type="checkbox"/> Others: Romanian or Russian
Documents to be submitted	<input checked="" type="checkbox"/> Duly Accomplished Form as provided in Annex 2, and in accordance with the list of requirements in Annex 1; <input checked="" type="checkbox"/> Company profile (short info up to 1 page); <input checked="" type="checkbox"/> Copy of Company's Registration Certificate; <input checked="" type="checkbox"/> Detailed technical description of the offered goods; <input checked="" type="checkbox"/> Quality Certificates (e.g. ISO, etc.) for the furniture and/or used materials (chipboard, melamine chipboard, accessories, etc.) in case the furniture is to be manufactured <input checked="" type="checkbox"/> Written Self-Declaration of not being included in the UN Security Council 1267/1989 list, UN Procurement Division List or other UN Ineligibility List.
Period of Validity of Quotes starting the Submission Deadline Date	<input checked="" type="checkbox"/> 60 days <input type="checkbox"/> 90 days <input type="checkbox"/> 120 days In exceptional circumstances, UNDP may request the Vendor to extend the validity of the Quotation beyond what has been initially indicated in this RFQ. The Proposal shall then confirm the extension in writing, without any modification whatsoever on the Quotation.
Partial Quotes	<input checked="" type="checkbox"/> Permitted by LOT
Payment Terms	<input checked="" type="checkbox"/> 100% upon complete delivery of goods
Liquidated Damages	0.1% of contract for every day of delay, up to a maximum duration of 1 calendar month. Thereafter, the contract may be terminated.
Evaluation Criteria	<input checked="" type="checkbox"/> Technical responsiveness/Full compliance to requirements and lowest price; <input checked="" type="checkbox"/> Minimum 3 year experience in the field; <input checked="" type="checkbox"/> Full acceptance of the PO/Contract General Terms and Conditions <input checked="" type="checkbox"/> Maximum delivery period not to exceed 21 calendar days upon signature of contract. <input checked="" type="checkbox"/> Warranty on Parts and Labor for minimum period of 1 year
UNDP will award to:	<input checked="" type="checkbox"/> One or more Supplier, depending on the evaluation results, which will be done per each Lot separately
Type of Contract to be Signed	<input checked="" type="checkbox"/> Purchase Order
Conditions for Release of Payment	<input checked="" type="checkbox"/> Written Acceptance of Goods based on full compliance with RFQ requirements
Annexes to this RFQ	<input checked="" type="checkbox"/> Specifications of the Goods Required (Annex 1) <input checked="" type="checkbox"/> Form for Submission of Quotation (Annex 2) <input checked="" type="checkbox"/> General Terms and Conditions / Special Conditions (Annex 3). Non-acceptance of the terms of the General Terms and Conditions (GTC) shall be grounds for disqualification from this procurement process.
Contact Person for Inquiries (Written inquiries only) <sup>2</sup>	Jana Midoni, Project Associate jana.midoni@undp.org

<sup>2</sup> This contact person and address is officially designated by UNDP. If inquiries are sent to other person/s or address/es, even if they are UNDP staff, UNDP shall have no obligation to respond nor can UNDP confirm that the query was received.

	Any delay in UNDP's response shall be not used as a reason for extending the deadline for submission, unless UNDP determines that such an extension is necessary and communicates a new deadline to the Proposers.
--	--

Goods offered shall be reviewed based on completeness and compliance of the quotation with the minimum specifications described above and any other annexes providing details of UNDP requirements.

The quotation that complies with all of the specifications, requirements and offers the lowest price, as well as all other evaluation criteria indicated, shall be selected. Any offer that does not meet the requirements shall be rejected.

Any discrepancy between the unit price and the total price (obtained by multiplying the unit price and quantity) shall be re-computed by UNDP. The unit price shall prevail and the total price shall be corrected. If the supplier does not accept the final price based on UNDP's re-computation and correction of errors, its quotation will be rejected.

After UNDP has identified the lowest price offer, UNDP reserves the right to award the contract based only on the prices of the goods in the event that the transportation cost (freight and insurance) is found to be higher than UNDP's own estimated cost if sourced from its own freight forwarder and insurance provider.

At any time during the validity of the quotation, no price variation due to escalation, inflation, fluctuation in exchange rates, or any other market factors shall be accepted by UNDP after it has received the quotation. At the time of award of Contract or Purchase Order, UNDP reserves the right to vary (increase or decrease) the quantity of services and/or goods, by up to a maximum twenty five per cent (25%) of the total offer, without any change in the unit price or other terms and conditions.

Any Purchase Order that will be issued as a result of this RFQ shall be subject to the General Terms and Conditions attached hereto. The mere act of submission of a quotation implies that the vendor accepts without question the General Terms and Conditions of UNDP herein attached as Annex 3.

UNDP is not bound to accept any quotation, nor award a contract/Purchase Order, nor be responsible for any costs associated with a Supplier's preparation and submission of a quotation, regardless of the outcome or the manner of conducting the selection process.

Please be advised that UNDP's vendor protest procedure is intended to afford an opportunity to appeal for persons or firms not awarded a purchase order or contract in a competitive procurement process. In the event that you believe you have not been fairly treated, you can find detailed information about vendor protest procedures in the following link: <http://www.undp.org/procurement/protest.shtml>.

UNDP encourages every prospective Vendor to avoid and prevent conflicts of interest, by disclosing to UNDP if you, or any of your affiliates or personnel, were involved in the preparation of the requirements, design, specifications, cost estimates, and other information used in this RFQ.



UNDP implements a zero tolerance on fraud and other proscribed practices, and is committed to identifying and addressing all such acts and practices against UNDP, as well as third parties involved in UNDP activities. UNDP expects its suppliers to adhere to the UN Supplier Code of Conduct found in this link: [http://www.un.org/depts/ptd/pdf/conduct\\_english.pdf](http://www.un.org/depts/ptd/pdf/conduct_english.pdf).

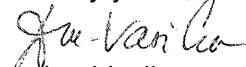

Thank you and we look forward to receiving your quotation.

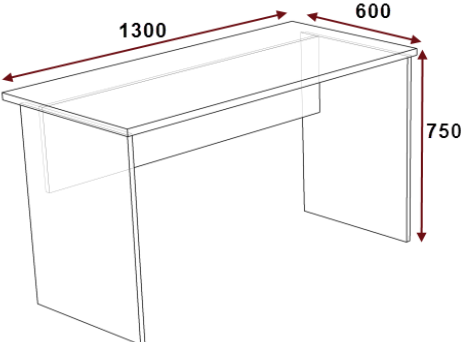

Sincerely yours,

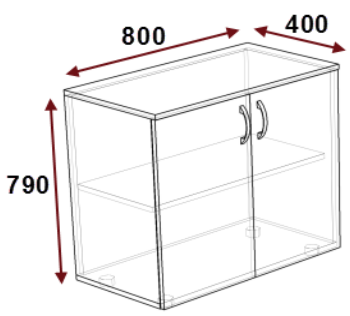

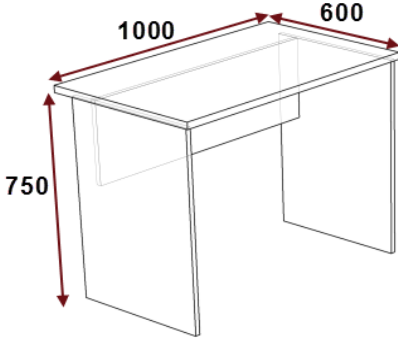
  
Dumitru Vasilescu,  
Project Manager

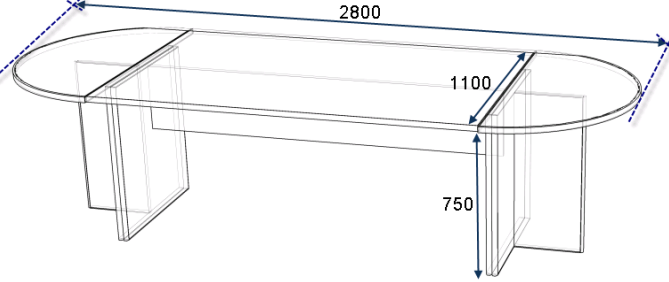
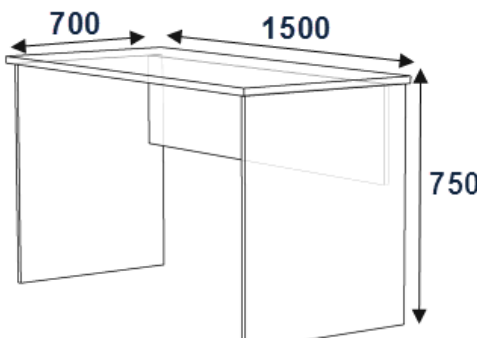
## Technical Specifications

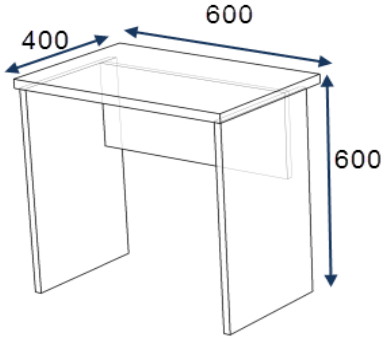
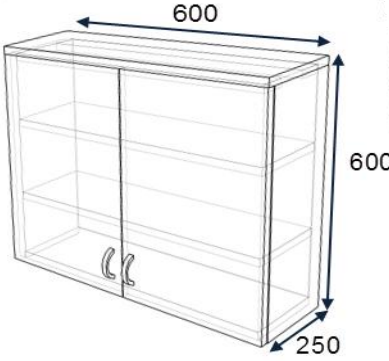
Items to be Supplied	Quantity	Description / Specifications of Goods	Latest Delivery Date
<b>LOT I</b>			
Item 1	2	 <p><b>Table 1300x600x750H</b> Tabletop - melamine chipboard 18mm / edge - PVC 2mm thick</p>	20 October, 2014
Item 2	3	 <p><b>Bookcase 800x400x2000H</b> Bookcase frame, doors &amp; shelves - melamine chipboard 18mm / edge - PVC 2mm thick / handles of bookcase - metal</p>	20 October, 2014
Item 3	3	 <p><b>Bookcase 800x400x790H</b> Bookcase frame, doors &amp; shelves - melamine chipboard 18mm / edge - PVC 2mm thick / handles of bookcase - metal</p>	20 October, 2014

<p>Item 4</p>	<p>27</p>	 <p><b>Table 1000x600x750H</b> Tabletop - melamine chipboard 18mm / edge - PVC 2mm thick</p>	<p>20 October, 2014</p>
<p>Item 5</p>	<p>1</p>	 <p><b>Wardrobe 800x400x2000H</b> Bookcase frame, doors &amp; shelves - melamine chipboard 18mm / edge - PVC 2mm thick / handles of bookcase - metal</p>	<p>20 October, 2014</p>
<p>Item 6</p>	<p>1</p>	 <p><b>Table 2800x1100x750H</b> melamine chipboard 18mm Tabletop 36 mm / edge - PVC 2mm thick</p>	<p>20 October, 2014</p>
<p>Item 7</p>	<p>3</p>		<p>20 October, 2014</p>

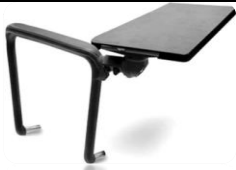
		<p><b>Table 1500x700x750H</b> tabletop - melamine chipboard 18mm / edge - PVC 2mm thick</p>	
Item 8	3	 <p><b>Mobile container 450x600x750H</b> melamine chipboard 18mm / edge - PVC 2mm thick / handles of bookcase - metal</p>	20 October, 2014
Item 9	1	 <p><b>Table 600x400x600H tabletop</b> melamine chipboard 18mm / edge - PVC 2mm thick</p>	20 October, 2014
Item 10	1	 <p><b>Bookcase 600x250x600H</b> Bookcase frame, doors &amp; shelves - melamine chipboard 18mm / edge - PVC 2mm thick / handles of bookcase - metal</p>	20 October, 2014
<b>LOT II</b>			
Item 11	41		20 October, 2014

		<p><b>Chair</b> Soft upholstered seat and backrest / Legs - metal Chromium plated /Gray color fabric</p>	
Item 12	30	 <p><b>Chair with mobile table on the armrest</b> Soft upholstered seat and backrest / Legs - metal Chromium plated /Gray color fabric/ Mobile table on the armrest PU</p>	20 October, 2014
Item 13	20	 <p><b>Armrest with table PU for chairs ISO</b></p>	10 October, 2014
Item 14	3	 <p><b>Armchair on wheels</b> Ergonomic backrest / Gray color fabric / Plastic arms</p>	20 October, 2014
Item 15	3	 <p><b>Coat hanger</b> made of chromium plated or powder coated metal frame. Chromium plated metal ring for umbrellas.</p>	20 October, 2014

## FORM FOR SUBMITTING SUPPLIER'S QUOTATION

*(This Form must be submitted only using the Supplier's Official Letterhead/Stationery<sup>3</sup>)*

We, the undersigned, hereby accept in full the UNDP General Terms and Conditions, and hereby offer to supply the items listed below in conformity with the specification and requirements of UNDP as per RFQ Reference No. RfQ14/00876: supply of furniture for SYSLAB Centre in Balti.

**TABLE 1 : Offer to Supply Goods Compliant with Technical Specifications and Requirements**

Item No.	Description/Specification of Goods	Detailed description of furniture (names, brands, codes, materials used, thickness, etc.)	Quantity	Latest Delivery Date	Unit Price	Total Price per Item
<b>LOT I</b>						
Item 1	Table 1300x600x750H		2			
Item 2	Bookcase 800x400x2000H		3			
Item 3	Bookcase 800x400x790H		3			
Item 4	Table 1000x600x750H		27			
Item 5	Wardrobe 800x400x2000H		1			
Item 6	Table 2800x1100x750H		1			
Item 7	Table 1500x700x750H		3			
Item 8	Mobile container 450x600x750H		3			
Item 9	Table 600x400x600H		1			
Item 10	Bookcase 600x250x600H		1			
<b>Total Prices of Goods<sup>4</sup>, LOT I</b>						
Add: Delivery and installation of the furniture at SYSLAB Centre in Balti, 13, Decebal str., 2nd floor. Note: items positions 9 and 10 should be delivered in the framework of Chisinau area.						
Add: Other Charges (pls. specify)						
					<b>Total, LOT I</b>	
<b>LOT II</b>						
Item 11	Chair with soft upholstered seat and backrest, legs - metal		41			
Item 12	Chair with soft		30			

<sup>3</sup> Official Letterhead/Stationery must indicate contact details – addresses, email, phone and fax numbers – for verification purposes

<sup>4</sup> Pricing of goods should be consistent with the INCO Terms indicated in the RFQ



	upholstered seat and mobile table on the armrest PU					
Item 13	Armrest with table PU for chairs ISO*		20			
Item 14	Armchair on wheels, with ergonomic backrest		3			
Item 15	Coat hanger with metal ring for umbrellas		3			
<b>Total Prices of Goods<sup>5</sup>, LOT II</b>						
Add: Delivery and installation of the furniture at the SYSLAB Centre in Balti, 13, Decebal str., 2nd floor (except position 13)						
Add: Delivery and installation of 20 armrests with table PU for chairs ISO at the SYSLAB Office in Cahul, 19, Dunarii str, 4th floor.						
Add : Other Charges (pls. specify)						
						<b>Total, LOT II</b>

**TABLE 2 : Offer to Comply with Other Conditions and Related Requirements**

Other Information pertaining to our Quotation are as follows :	Your Responses		
	<i>Yes, we will comply</i>	<i>No, we cannot comply</i>	<i>If you cannot comply, pls. indicate counter proposal</i>
Delivery Lead Time			
Warranty and After-Sales Requirements			
a) Minimum one (1) year warranty on both parts and labor			
b) Fixing/assembling of furniture in the office premises			
Validity of Quotation: 60 calendar days			
All Provisions of the UNDP General Terms and Conditions			

All other information that we have not provided automatically implies our full compliance with the requirements, terms and conditions of the RFQ.

*[Name and Signature of the Supplier's Authorized Person]  
[Designation]  
[Date]*

<sup>5</sup> Pricing of goods should be consistent with the INCO Terms indicated in the RFQ

## **General Terms and Conditions**

### **1. ACCEPTANCE OF THE PURCHASE ORDER**

This Purchase Order may only be accepted by the Supplier's signing and returning an acknowledgement copy of it or by timely delivery of the goods in accordance with the terms of this Purchase Order, as herein specified. Acceptance of this Purchase Order shall effect a contract between the Parties under which the rights and obligations of the Parties shall be governed solely by the terms and conditions of this Purchase Order, including these General Conditions. No additional or inconsistent provisions proposed by the Supplier shall bind UNDP unless agreed to in writing by a duly authorized official of UNDP.

### **2. PAYMENT**

- 2.1 UNDP shall, on fulfillment of the Delivery Terms, unless otherwise provided in this Purchase Order, make payment within 30 days of receipt of the Supplier's invoice for the goods and copies of the shipping documents specified in this Purchase Order.
- 2.2 Payment against the invoice referred to above will reflect any discount shown under the payment terms of this Purchase Order, provided payment is made within the period required by such payment terms.
- 2.3 Unless authorized by UNDP, the Supplier shall submit one invoice in respect of this Purchase Order, and such invoice must indicate the Purchase Order's identification number.
- 2.4 The prices shown in this Purchase Order may not be increased except by express written agreement of UNDP.

### **3. TAX EXEMPTION**

- 3.1 Section 7 of the Convention on the Privileges and Immunities of the United Nations provides, inter alia, that the United Nations, including its subsidiary organs, is exempt from all direct taxes, except charges for utilities services, and is exempt from customs duties and charges of a similar nature in respect of articles imported or exported for its official use. In the event any governmental authority refuses to recognize UNDP's exemption from such taxes, duties or charges, the Supplier shall immediately consult with UNDP to determine a mutually acceptable procedure.
- 3.2 Accordingly, the Supplier authorizes UNDP to deduct from the Supplier's invoice any amount representing such taxes, duties or charges, unless the Supplier has consulted with UNDP before the payment thereof and UNDP has, in each instance, specifically authorized the Supplier to pay such taxes, duties or charges under protest. In that event, the Supplier shall provide UNDP with written evidence that payment of such taxes, duties or charges has been made and appropriately authorized.

### **4. RISK OF LOSS**

Risk of loss, damage to or destruction of the goods shall be governed in accordance with Incoterms 2010, unless otherwise agreed upon by the Parties on the front side of this Purchase Order.

### **5. EXPORT LICENCES**

Notwithstanding any INCOTERM 2010 used in this Purchase Order, the Supplier shall obtain any export licences required for the goods.

### **6. FITNESS OF GOODS/PACKAGING**

The Supplier warrants that the goods, including packaging, conform to the specifications for the goods ordered under this Purchase Order and are fit for the purposes for which such goods are ordinarily used and for purposes expressly made known to the Supplier by UNDP, and are free from defects in workmanship and materials. The Supplier also warrants that the goods are contained or packaged adequately to protect the goods.

## **7. INSPECTION**

- 7.1 UNDP shall have a reasonable time after delivery of the goods to inspect them and to reject and refuse acceptance of goods not conforming to this Purchase Order; payment for goods pursuant to this Purchase Order shall not be deemed an acceptance of the goods.
- 7.2 Inspection prior to shipment does not relieve the Supplier from any of its contractual obligations.

## **8. INTELLECTUAL PROPERTY INFRINGEMENT**

The Supplier warrants that the use or supply by UNDP of the goods sold under this Purchase Order does not infringe any patent, design, trade-name or trade-mark. In addition, the Supplier shall, pursuant to this warranty, indemnify, defend and hold UNDP and the United Nations harmless from any actions or claims brought against UNDP or the United Nations pertaining to the alleged infringement of a patent, design, trade-name or trade-mark arising in connection with the goods sold under this Purchase Order.

## **9. RIGHTS OF UNDP**

In case of failure by the Supplier to fulfil its obligations under the terms and conditions of this Purchase Order, including but not limited to failure to obtain necessary export licences, or to make delivery of all or part of the goods by the agreed delivery date or dates, UNDP may, after giving the Supplier reasonable notice to perform and without prejudice to any other rights or remedies, exercise one or more of the following rights:

- 9.1 Procure all or part of the goods from other sources, in which event UNDP may hold the Supplier responsible for any excess cost occasioned thereby.
- 9.2 Refuse to accept delivery of all or part of the goods.
- 9.3 Cancel this Purchase Order without any liability for termination charges or any other liability of any kind of UNDP.

## **10. LATE DELIVERY**

Without limiting any other rights or obligations of the parties hereunder, if the Supplier will be unable to deliver the goods by the delivery date(s) stipulated in this Purchase Order, the Supplier shall (i) immediately consult with UNDP to determine the most expeditious means for delivering the goods and (ii) use an expedited means of delivery, at the Supplier's cost (unless the delay is due to Force Majeure), if reasonably so requested by UNDP.

## **11. ASSIGNMENT AND INSOLVENCY**

- 11.1. The Supplier shall not, except after obtaining the written consent of UNDP, assign, transfer, pledge or make other disposition of this Purchase Order, or any part thereof, or any of the Supplier's rights or obligations under this Purchase Order.
- 11.2. Should the Supplier become insolvent or should control of the Supplier change by virtue of insolvency, UNDP may, without prejudice to any other rights or remedies, immediately terminate this Purchase Order by giving the Supplier written notice of termination.

## **12. USE OF UNDP OR UNITED NATIONS NAME OR EMBLEM**

The Supplier shall not use the name, emblem or official seal of UNDP or the United Nations for any purpose.

### **13. PROHIBITION ON ADVERTISING**

The Supplier shall not advertise or otherwise make public that it is furnishing goods or services to UNDP without specific permission of UNDP in each instance.

### **14. CHILD LABOUR**

The Supplier represents and warrants that neither it nor any of its affiliates is engaged in any practice inconsistent with the rights set forth in the Convention on the Rights of the Child, including Article 32 thereof, which, inter alia, requires that a child shall be protected from performing any work that is likely to be hazardous or to interfere with the child's education, or to be harmful to the child's health or physical, mental, spiritual, moral or social development.

Any breach of this representation and warranty shall entitle UNDP to terminate this Purchase Order immediately upon notice to the Supplier, without any liability for termination charges or any other liability of any kind of UNDP.

### **15. MINES**

The Supplier represents and warrants that neither it nor any of its affiliates is actively and directly engaged in patent activities, development, assembly, production, trade or manufacture of mines or in such activities in respect of components primarily utilized in the manufacture of Mines. The term "Mines" means those devices defined in Article 2, Paragraphs 1, 4 and 5 of Protocol II annexed to the Convention on Prohibitions and Restrictions on the Use of Certain Conventional Weapons Which May Be Deemed to Be Excessively Injurious or to Have Indiscriminate Effects of 1980.

Any breach of this representation and warranty shall entitle UNDP to terminate this Purchase Order immediately upon notice to the Supplier, without any liability for termination charges or any other liability of any kind of UNDP.

### **16. SETTLEMENT OF DISPUTES**

16.1 **Amicable Settlement.** The Parties shall use their best efforts to settle amicably any dispute, controversy or claim arising out of, or relating to this Purchase Order or the breach, termination or invalidity thereof. Where the Parties wish to seek such an amicable settlement through conciliation, the conciliation shall take place in accordance with the UNCITRAL Conciliation Rules then obtaining, or according to such other procedure as may be agreed between the Parties.

16.2 **Arbitration.** Unless, any such dispute, controversy or claim between the Parties arising out of or relating to this Purchase Order or the breach, termination or invalidity thereof is settled amicably under the preceding paragraph of this Section within sixty (60) days after receipt by one Party of the other Party's request for such amicable settlement, such dispute, controversy or claim shall be referred by either Party to arbitration in accordance with the UNCITRAL Arbitration Rules then obtaining, including its provisions on applicable law. The arbitral tribunal shall have no authority to award punitive damages. The Parties shall be bound by any arbitration award rendered as a result of such arbitration as the final adjudication of any such controversy, claim or dispute.

### **17. PRIVILEGES AND IMMUNITIES**

Nothing in or related to these General Terms and Conditions or this Purchase Order shall be deemed a waiver of any of the privileges and immunities of the United Nations, including its subsidiary organs.

**18. SEXUAL EXPLOITATION:**

- 18.1 The Contractor shall take all appropriate measures to prevent sexual exploitation or abuse of anyone by it or by any of its employees or any other persons who may be engaged by the Contractor to perform any services under the Contract. For these purposes, sexual activity with any person less than eighteen years of age, regardless of any laws relating to consent, shall constitute the sexual exploitation and abuse of such person. In addition, the Contractor shall refrain from, and shall take all appropriate measures to prohibit its employees or other persons engaged by it from, exchanging any money, goods, services, offers of employment or other things of value, for sexual favors or activities, or from engaging in any sexual activities that are exploitive or degrading to any person. The Contractor acknowledges and agrees that the provisions hereof constitute an essential term of the Contract and that any breach of this representation and warranty shall entitle UNDP to terminate the Contract immediately upon notice to the Contractor, without any liability for termination charges or any other liability of any kind.
- 18.2 UNDP shall not apply the foregoing standard relating to age in any case in which the Contractor's personnel or any other person who may be engaged by the Contractor to perform any services under the Contract is married to the person less than the age of eighteen years with whom sexual activity has occurred and in which such marriage is recognized as valid under the laws of the country of citizenship of such Contractor's personnel or such other person who may be engaged by the Contractor to perform any services under the Contract.

**19. OFFICIALS NOT TO BENEFIT:**

The Contractor warrants that no official of UNDP or the United Nations has received or will be offered by the Contractor any direct or indirect benefit arising from this Contract or the award thereof. The Contractor agrees that breach of this provision is a breach of an essential term of this Contract.

**20. AUTHORITY TO MODIFY:**

Pursuant to the Financial Regulations and Rules of UNDP, only the UNDP Authorized Official possess the authority to agree on behalf of UNDP to any modification of or change in this Agreement, to a waiver of any of its provisions or to any additional contractual relationship of any kind with the Contractor. Accordingly, no modification or change in this Contract shall be valid and enforceable against UNDP unless provided by an amendment to this Agreement signed by the Contractor and jointly by the UNDP Authorized Official.